



### Module for emergency stops, end position monitoring for movable guards, safety mats and safety bumpers with 4-wire technology

#### Main features

- For safety applications up to SIL CL 3/PL e
- Input with 2 channels
- Choice between automatic start, manual start or monitored start
- Connection of input channels of opposite potentials
- Can be connected to electromechanical contacts, safety mats or safety bumpers with 4-wire technology
- Output contacts:  
2 NO safety contacts,
- Supply voltage:  
24 Vac/dc

#### Utilization categories

Alternating current: AC15 (50...60 Hz)

U<sub>e</sub> (V) 230

I<sub>e</sub> (A) 3

Direct current: DC13 (6 oper. cycles/min.)

U<sub>e</sub> (V) 24

I<sub>e</sub> (A) 4

#### Quality marks and certificates:



EC type examination certificate: IMQ CP 432 DM

UL approval: E131787

CCC approval: 2013010305640211

EAC approval: RU C-IT.AJ35.B.00454

#### Compliance with the requirements of:

Low Voltage Directive 2014/35/EU,

Machinery Directive 2006/42/EC,

EMC Directive 2014/30/EU

### Technical data

#### Housing

Polyamide housing PA 66, self-extinguishing V0 acc. to UL 94

Protection degree:

IP40 (housing), IP20 (terminal strip)

Dimensions:

see page 295, design A

#### General data

SIL CL:

up to SIL CL 3 acc. to EN 62061

Performance Level (PL):

up to PL e acc. to EN ISO 13849-1

Safety category:

up to cat. 4 acc. to EN ISO 13849-1

Safety parameters:

see page 349

Ambient temperature:

-25°C...+55°C

Mechanical endurance:

>10 million operating cycles

Electrical endurance:

>100,000 operating cycles

Pollution degree:

external 3, internal 2

Impulse withstand voltage (U<sub>imp</sub>):

4 kV

Rated insulation voltage (U<sub>i</sub>):

250 V

Overtoltage category:

II

Weight:

0.3 kg

#### Supply

Rated supply voltage (U<sub>n</sub>):

24 Vac/dc; 50...60 Hz

Max. DC residual ripple in DC:

10%

Supply voltage tolerance:

±15% of U<sub>n</sub>

Power consumption AC:

< 5 VA

Power consumption DC:

< 2.5 W

#### Control circuit

Protection against short circuits:

PTC resistance, I<sub>h</sub>=0.5 A

PTC times:

Response time > 100 ms, release time > 3 s

Maximum resistance per input:

≤ 200 Ω

Current per input:

10 mA (typical)

Min. duration of start impulse t<sub>MIN</sub>:

> 150 ms

Response time t<sub>A</sub>:

< 120 ms

Release time t<sub>R1</sub>:

< 15 ms

Release time in absence of power supply t<sub>R</sub>:

< 100 ms

Simultaneity time t<sub>C</sub>:

unlimited

#### In compliance with standards:

EN 60204-1, EN ISO 13855, EN 1037, EN ISO 12100, EN ISO 13850, EN 60529,

EN 61000-6-2, EN 61000-6-3, EN 61326-1, EN 60664-1, EN 60947-1, EN ISO 13849-1,

EN ISO 13849-2, EN 62061, UL 508, CSA C22.2 n° 14-95

#### Output circuit

Output contacts:

2 NO safety contacts

Contact type:

forcibly guided

Material of the contacts:

gold-plated silver alloy

Maximum switching voltage:

230/240 Vac; 300 Vdc

Max. current per contact:

6 A

Conventional free air thermal current (I<sub>th</sub>):

6 A

Max. total current Σ I<sub>th</sub><sup>2</sup>:

36 A<sup>2</sup>

Minimum current:

10 mA

Contact resistance:

≤ 100 mΩ

External protection fuse:

4 A

The number and the load capacity of output contacts can be increased by using expansion modules or contactors. see page 241-250.

### Code structure

## CS AR-51V024

#### Connection type

<b>V</b>	Screw terminals
<b>M</b>	Connector with screw terminals
<b>X</b>	Connector with spring terminals

#### Supply voltage

**024** 24 Vac/dc

### Stock items

CS AR-51V024

#### Features approved by UL

Rated supply voltage (U <sub>n</sub> ):	24 Vac/dc; 50...60 Hz
Power consumption AC:	< 5 VA
Power consumption DC:	< 2 W
Maximum switching voltage:	230 Vac
Max. current per contact:	6 A
Utilization category	C300

#### Notes:

- Use 60 or 75 °C copper (Cu) conductors, rigid or flexible, wire size 30-12 AWG.
- Tightening torque for terminal screws of 5-7 lb in.
- Only for 24 Vac/dc versions: power supply only with class 2 sources or with limited voltage and energy. (Supply from Remote Class 2 Source or limited voltage limited energy).



### Safety module CS AR-51

#### Pin assignment

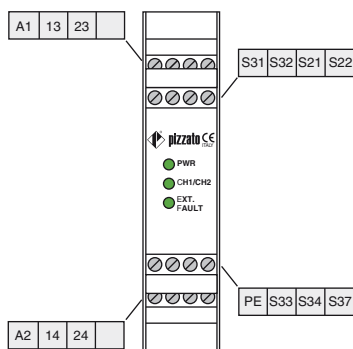

#### PE terminal connection

The PE terminal has to be connected to the equipotential circuit of machine protection if it is necessary. This connection is made for functional reason, to reduce effects of an insulation fault on the machine operation. In particular, ground faults in control circuits must not cause unwanted start-up or dangerous movements or prevent the machine from stopping.

#### Function of "EXT. FAULT" LED

When a pressure is exerted on the surface of a safety bumper or safety mat, a short-circuit occurs between the two conductive elements, which constitute the apparatus and can be connected to the input channels of the safety module.

The signal thereby generated causes the EXT.FAULT LED to illuminate and signal the short-circuit and the opening of the output contacts, resulting in the blocking of the control circuit and causing the machine to switch to the safety setting. The EXT. FAULT LED does not switch on if the wires or internal connections of the safety mat or safety bumper are interrupted.

#### Internal block diagram

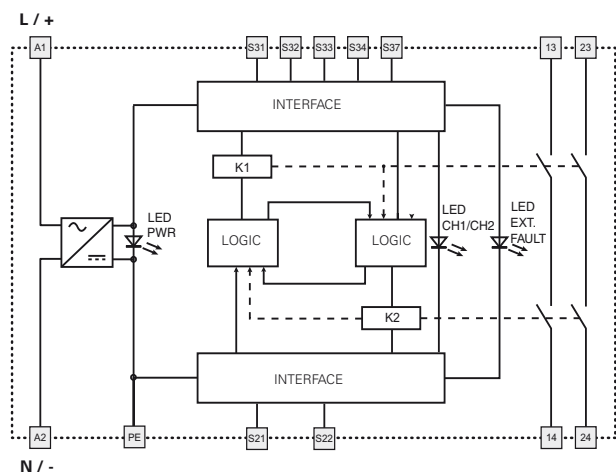

#### Input configuration

##### Safety mats and safety bumpers

##### Input configuration with manual start

2 channels

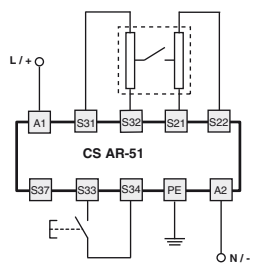

##### Emergency stop circuits

##### Input configuration with manual start

2 channels

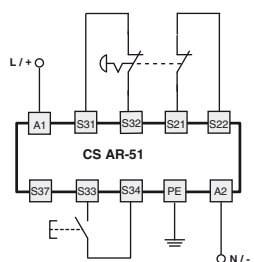

#### Function diagrams

##### Configuration with automatic start

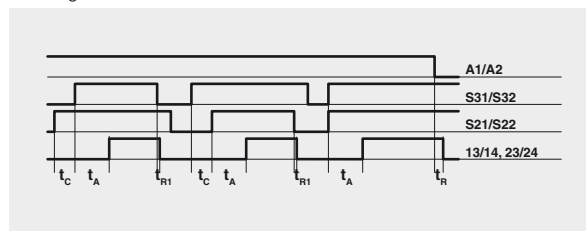

##### Configuration with monitored start

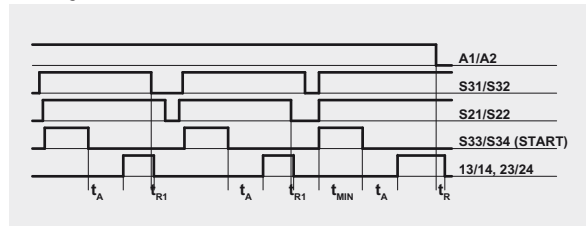

##### Configuration with manual start

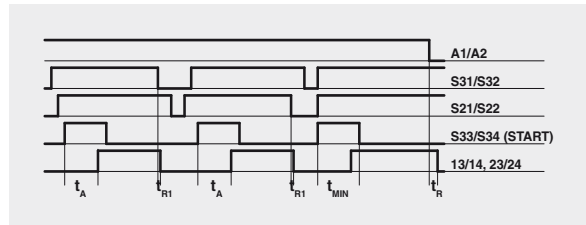

#### Legend:

- $t_{MIN}$ : Min. duration of start impulse
- $t_C$ : simultaneity time
- $t_A$ : response time
- $t_{R1}$ : release time
- $t_R$ : release time in absence of power supply

#### Automatic start

With regard to the indicated diagrams, bridge the start button between S33 and S34 in order to activate the automatic start module.

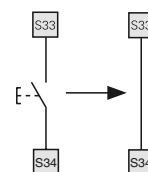

#### Monitored start

With regard to the indicated diagrams, establish the connection between S34 and S37 in order to activate the monitored start module.

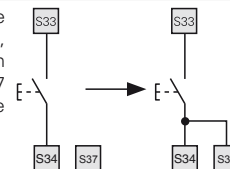

#### Movable guard monitoring

The safety module can monitor emergency stop circuits and control circuits for movable guards. Replace the emergency stop contacts with the switch contacts.

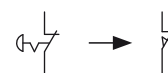

The diagram does not show the exact position of the terminals in the product

Items with code on **green** background are stock items